

# CONSTRUCTION PLANNING OF THE UPPER STRUCTURE OF THE PKP-PK BUILDING AT HUSEIN SASTRANEGARA AIRPORT BANDUNG

Syahumi Ramadhan Hasibuan\*, Bambang Wasito, Karina Meilawati

*Politeknik Penerbangan Surabaya, Jl. Jemur Andayani I No 73 Surabaya, 60236*

*\*Corresponding Author. Email: [syahumi2006@gmail.com](mailto:syahumi2006@gmail.com)*

## ABSTRACT

The PKP-PK building is one of the facilities located at an airport to visually monitor aircraft movements. In connection with this, at Husein Sastranegara Airport Bandung there is a PKP-PK building. In this study, it is intended to plan the PKP-PK building structure in accordance with SNI. so that in analyzing the structure, the SRPMK (Special Moment Bearing Frame System) method is used. In the calculation of the structure used SRPMK (Special Moment Bearing Frame System) and Strong Column Weak Beam which refers to SNI 1726: 2019 concerning earthquakes. In planning the building structure, SNI 2847: 2019 concerning reinforced concrete and SNI 1727: 2018 for loading are used. In this research, the SAP 2000 auxiliary program is used for 3D building modeling, PCAColumn for column interaction diagram calculation, and Autocad 2018 for reinforcement details. In the planning, 400/600mm main beam, with 5 D 19 flexural reinforcement at positive moment, at 7 D 19 flexural reinforcement at negative moment, 300/500mm sub-beam, with 3 D 16 flexural reinforcement at positive moment, at 5 D 16 flexural reinforcement at negative moment, 200/300 sub-beam with 3 D 13 flexural reinforcement at positive moment, at 5 D 13 flexural reinforcement at negative moment 600/600 column and 100 mm plate thickness and structural reinforcement details are included in the engineering drawings. In addition, the PKP-PK structural design control check based on SNI 1726: 2019 has met the requirements and fulfills the Strong Column Weak Beam concept and the cost required for the PKP-PK building construction planning is Rp1,324,860,000.00 (One Billion Three Hundred Twenty Four Million Eight Hundred Sixty Thousand Rupiah).

**Keywords:** SRPMK, PKP-PK, Strong Column Weak Beam, Husein Sastranegara Airport Bandung.

## INTRODUCTION

Husein Sastranegara International Airport (IATA: BDO, ICAO: WICC) is an international airport located at Jalan Pajajaran Number. 156, Husein Sastranegara village, Cicendo sub-district, Bandung city (capital of West Java Province), with coordinates 06o 54' 07 LS - 107o 34' 34 East and elevation 2445 ft (742m). In 1974, the activities of commercial air traffic and transportation services began to be carried out officially, namely with the establishment of the Representative office of the Directorate General of Civil Aviation with the name Husein Sastranegara Bandung Air Station for the benefit of civil commercial aviation activities. Furthermore, in 1983 based on the Decree of the Minister of

Transportation Number: KM68/HK207/PHB-83 Dated February 19, 1983, the airport clarification was upgraded from class III to Class II. In 1994 on August 30, 1994 regarding the addition of the capital participation of the State of Indonesia into the Share Capital of PT Angkasa Pura II (Source: [angkasapura2.co.id](http://angkasapura2.co.id)).

PKP-PK building is located on the air side with a strategic placement location based on the calculation of reaction time (Response Time) which functions as a center for controlling and implementing PKP-PK and Salvage operation activities. Based on the Director General of Air Transportation Regulation No. KP 420 Year 2011, every fire station is located on the airside: KP 420 Year 2011, each fire station must be equipped with a

watchroom that functions as a place to visually monitor the movement of aircraft free of obstructions and must be equipped with, among others, communication equipment, alarm systems, monitoring aids (voice and / or visual), voice recording equipment systems (voice, radio base, crash bell, telephone and intercom) 1 . The current condition of the fire station is not as required.

Husein Sastranegara Airport is an airport located in the city of Bandung, West Java. Husein Sastranegara Airport with the 4C Airport category has a classification of PKP-PK facilities and infrastructure category 7. To support facilities and operations, appropriate infrastructure is needed, while for PKP-PK car park conditions have dimensions of 32 m x 13 m and the distance between columns is 3.5 m x 13 m. Observation of the existing watchroom is also less than optimal due to its unstrategic location. Observation of the existing watchroom is also less than optimal due to the location that is not strategic. For this reason, an appropriate watchroom design must be planned so that it can monitor the entire aircraft movement area. Therefore, the PKP-PK building renovation is carried out so that performance can be optimized. Based on these conditions, this research is systematically organized into a research entitled, "CONSTRUCTION PLANNING OF THE TOP STRUCTURE OF THE PKP-PK BUILDING AT HUSEIN SASTRANEGARA BANDUNG AIRPORT".

According to Syamszadeh. M. M. (2022) with the title "Evaluation of Strong Column-Weak Beam Criteria in Columns Associated with Steel Frames". This criterion is called strong-column-weak girder (SCWB) in seismic design regulations and is confirmed by the formula as the ratio of the total bending capacity of the column to the truss beam at each washer. Usually we ignore the change of column cross-section at the connection point and use the maximum cross-sectional bending capacity of the column to estimate this ratio. The results show that the response to the SCWB ratio with a larger column cross-section results in plastic joints forming in the column earlier and exerting a smaller resisting force.

According to Prianto. K. (202) with the title "Disaster Resilience In Building Construction Through Concrete Casting Methods: Implications For The Use Of Strong Columns And Weak Beams," observations were made about the construction of a four-story concrete building. The analysis compares the entire ready-mixed concrete work carried out by one supplier with that using another supplier for each of the different parts of the building structure. The data used are the compressive strength test results of column and beam castings. From the data, plot the compressive strength of beam castings and compare it with the compressive strength graph of column castings. The results concluded that using different suppliers for casting different building components would have a higher chance of producing low-strength column-beam structures.

According to Gao. L, Xue. J.Y. (2014) on the topic of "Static and elastic analysis testing of middle trusses with special-shaped columns made of solid reinforced concrete", Based on experience, building an analytical model of elastic-flexibility of experimental frames using the SAP2000 program will be comparatively discussed. It has been proved that the analytical model built with plastic fiber hinges is more effective in analyzing the elastic-plastic behavior of a frame in general. Some of these laws can be summarized as follows: when the column height ratio or the beam-to-column elastic bending moment ratio increases, the horizontal bearing capacity of the truss increases significantly; with the increase of the height-thickness ratio of column elements, the stiffness of the truss increases significantly. The ductility of the frame hardly changes when the height-thickness ratio of column braces, the yield strength of steel or the beam-to-column elastic bending moment ratio change.

The problem formulation of this research is how to plan the PKP-PK building at the airport husein sastranegara bandung with the following formulation:

1. How is the design of the upper structure of the PKP-PK building at Husein Sastranegara Airport Bandung using the SAP 2000 application?
2. How to plan the structure of the Earthquake-resistant PKP-PK building according to Indonesian National Standard 1726: 2019?
3. How to analyze the upper structure of the PKP-PK building using the SAP 2000 program?
4. What is the cost budget required for the renovation of the PKP-PK building at Husein Sastranegara Bandung airport?

## METHOD

### Data

As a basis for working on the research report, data is needed about everything related to the project. To obtain these data, several methods were used, as follows:

1. Direct observation as primary data Is a primary data collection method, namely observing directly when work is carried out. The visual data can support an understanding of the written data of the project as well as the work sequence of a work implementation. Also noted are things that have never been obtained, due to varying field conditions.
2. Collection of written project data as secondary data This data contains technical information about the project and can also be used as one of the bases for compiling the steps of a project work so that the data is to support existing primary data such as drawings, unit prices for wages and materials, and unit prices for work.

3. Literature Study Is a way of collecting data by reading or studying literature books that have to do with everything needed for the preparation of research.
4. General data
  - a. Building Name: PKP-PK Building
  - b. Location :Husein Sastranegara Airport
  - c. Function :a place to monitor aircraft movements and control the activities of fire fighting vehicles
  - d. Number of floors: 2
  - e. Building height:  $\pm 10\text{m}$

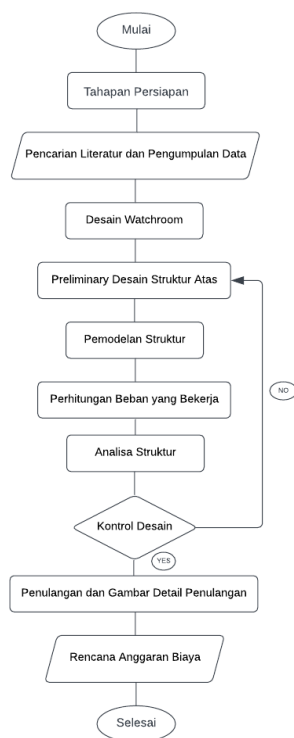

Figure 1 Flow Chart

### Cost Budget Plan

RAB (Cost Budget Plan) is the amount of money needed for both wages and materials in a construction project work, both houses, buildings, bridges, and others. By calculating RAB before carrying out construction work, it can reduce cost or labor overruns, so that we can get maximum results at an efficient cost. The steps to calculate RAB are as follows:

1. Defining work items. Before calculating the volume, first describe the work into the form of work items. What will be done in calculating the Budget Cost Plan (RAB).
2. Calculating the volume of structural work. After identifying the work items, then start to calculate the volume of each work item.

3. Finding the latest unit price list for wages and materials according to the provisions of each region. This time using the "Estimated Basic Unit Price of Large Cities in Indonesia Journal of Unit Price Database (Division IV Cipta Karya) West Java Province.
4. Analyze the unit price of work per work item. Is the calculation of the need for materials, wages and tools per work item. To make a work analysis the word can directly refer to SNI.
5. Prepare a Cost Budget Plan. After the above series of work has been completed, the next step is to compile a Cost Budget Plan (RAB).

## RESULTS AND DISCUSSION

### Preliminary Cross-Sectional Design

Preliminary design is the initial planning to determine the dimensions of the building structure. Preliminary design is carried out on primary and secondary structures including columns, beams and plates.

#### Material Data

##### a. Concrete Material

Concrete Quality	K = 300
Concrete compressive strength	$f_c' = 25.00 \text{ MPa}$
Modulus of elasticity	$E_c = 23500 \text{ MPa}$

##### b. Steel Material

Elastic modulus	$E_s = 200000 \text{ MPa}$
BJTD 40 (Threaded Tul)	
Yield stress of steel	$f_y = 390.00 \text{ MPa}$
Ultimate stress	$f_u = 560.00 \text{ MPa}$
BJPT 24 (Plain Tul.)	
Steel yield stress	$f_y = 240.00 \text{ MPa}$
Ultimate stress	$f_u = 360.00 \text{ MPa}$

### loading

#### a. Dead Load

The weight of all installed building construction materials, including walls, floors, roofs, ceilings, stairs, fixed partition walls, finishes and other architectural and structural components and other installed service equipment including the weight of cranes and material transport systems. The dead load/self weight of these structural elements will be calculated automatically.

#### b. Live Load

Loads caused by users and occupants of buildings or other structures that do not include construction loads and environmental loads, such as wind loads, earthquake loads, flood loads or dead loads.

**c. Seismic Load**

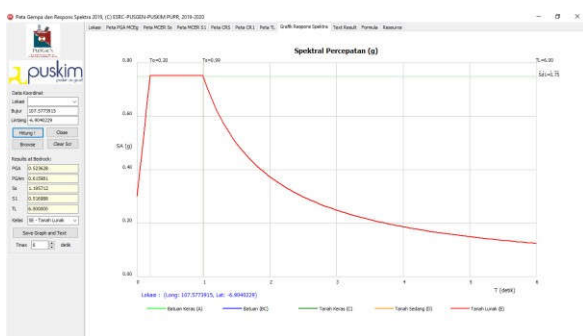

**Figure 2** Spectrum Response Graph

Based on the soil data, the site class = E is obtained so that the following data is obtained through RSA Puskim:

- SS = 1.1976
- S1 = 0.5176
- SDS = 0.7185
- SD1 = 0.8281

**Structure Modeling**

For SAP2000 modeling which can be seen in Figure 3

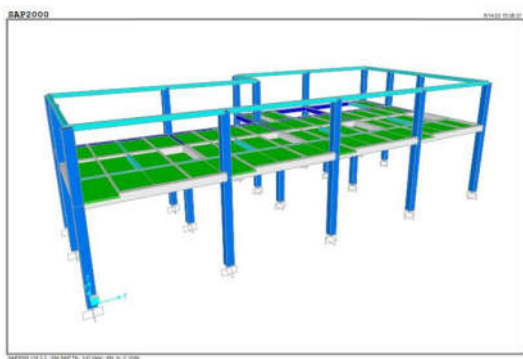

**Figure 3** 3D Structure Modeling

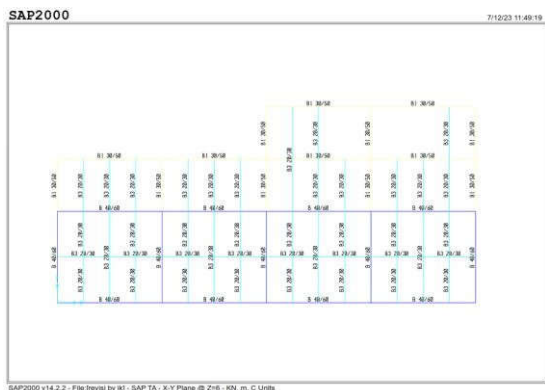

**Figure 4** Modeling of 1st Floor Beams

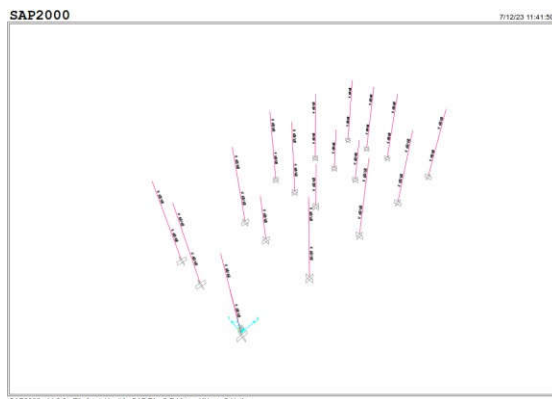

**Figure 5** Column Modeling K50

**SRPMK Beam Design SNI 2847 2019**

SRPMK beam design according to SNI 2847-2019 explains some general requirements. The beams that will be designed are B1 beams measuring 400 x 600 mm, B2 beams measuring 300 x 500 mm, and B3 beams measuring 200 x 300 mm.

KODE BALOK	B.1000	B.1500	B.2000	B.3000	B.3000
DIMENSI (mm)	400 x 600	400 x 600	300 x 500	300 x 500	200 x 300
TUL. LENTUR	12 - D19	12 - D19	12 - D19	12 - D19	12 - D19
TUL. LENTUR	12 - D19	12 - D19	12 - D19	12 - D19	12 - D19
TUL. LENTUR	12 - D19	12 - D19	12 - D19	12 - D19	12 - D19
BEUGEL	D10 - 150	D10 - 150	D10 - 150	D10 - 150	D10 - 150
DECKING (mm)	30	30	30	30	30

**Figure 6** Beam Reinforcement Detail

**Column Design K1**

The cross-sectional dimension requirements are regulated by SNI 2847-2019. The column to be designed is 500 x 500 mm.

KODE KOLOM	K 50/50
DIMENSI (mm)	500 x 500
TUL. LENTUR	12 - D19
BEUGEL	D10 - 150
DECKING (mm)	30

**Figure 7** Column Reinforcement Detail

**SRPMK Plate Design according to SNI 2847-2019**

SRPMK plate design according to SNI 2847-2019. The plates that will be designed

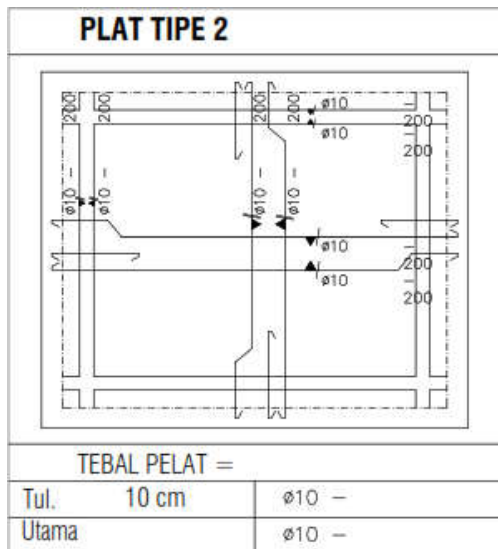

Figure 8 Floor Plate Reinforcement Details

**Calculation of SCWB Requirements**

$$\begin{aligned}
 \Sigma M_{nc} &\geq 1.2 \Sigma M_{nb} \\
 2 M_{nc} &\geq 1.2 (M_{nb}^+ + M_{nb}^-) \\
 824.89 &\geq 743.76 \quad (SCWB)
 \end{aligned}$$

**Calculation of Channel Length**

$$\begin{aligned}
 \lambda &= 1 \\
 \Psi_c &= 1 \\
 \Psi_c &= 1 \\
 \Psi_t &= 1 \\
 f_y &= 400 \text{ MPa} \\
 f_c &= 25 \text{ MPa} \\
 db &= 19 \text{ mm} \\
 l_{dh} &= \frac{(f_y * \Psi_t * \Psi_c)}{(1.4 * \lambda * \text{sqrt } f_c')} \text{ db} \\
 &= \frac{1085.714286}{1.09} \text{ mm} \\
 &= 1.09 \text{ m}
 \end{aligned}$$

**Cost Budget Planning**

Cost Budget Planning refers to the unit price of West Java Province and the cost required is Rp1,324,860,000.00 (One Billion Three Hundred Twenty Four Million Eight Hundred Sixty Thousand Rupiah).

**CONCLUSION**

**A.CONCLUSION**

Based on the results of the analysis of the watchroom structure planning at Husein Sastranegara Airport

Bandung using the SRPMK method, the following conclusions can be obtained:

1. The PKP-PK building structure consists of 2 floors with a total height of 10 m, building dimensions 32 x 15 m. The building structure uses a reinforced concrete structure with the Special Moment Bearing Frame System (SRPMK) method.
2. The column structure planning has fulfilled the Strong Column Weak Beam concept where the value of  $\Sigma M_{nc} = 824.89 \text{ kNm} \geq 1.2 \Sigma M_{nb} = 743.76 \text{ kNm}$ , so that the structure is able to deform during an earthquake (has high ductility). Figures and tables should be placed either at the top or bottom of the page and close to the text referring to them if possible.
3. The structural planning of the PKP-PK building obtained the following concrete design:
  - a. In the planning of the main beam with dimensions of 30 x 50 cm, with 3 D 16 flexural reinforcement at positive moment, 5 D 16 flexural reinforcement at negative moment and 2 P 10-150 stirrups.
  - b. In the planning of child beams with dimensions of 20 x 30 cm, with 3 D 13 flexural reinforcement at positive moments, 5 D 13 flexural reinforcement at negative moments and 2 P 10-120 stirrups.
  - c. In the planning of main beams with dimensions of 40 x 60 cm, with 5 D 19 flexural reinforcement at positive moments, 7 D 19 flexural reinforcement at negative moments and 2 P 10-150 stirrups.
  - d. In the planning of columns with dimensions of 60 x 60 cm with 12 D 19 flexural reinforcement and the number of stirrups 2 P 10 - 150 mm in the shear reinforcement area.
4. The cost required for the construction planning of the PKP-PK building is Rp 1,324,860,000.00 (One Billion Three Hundred Twenty Four Million Eight Hundred Sixty Thousand Rupiah).

**B. Advice**

From the results of the analysis during this research process, there are several suggestions submitted, among others:

1. It is expected that the Husein Sastranegara Airport Bandung to immediately improve the PKP-PK building because its existence is needed related to flight security and safety.
2. Future research can add calculations of foundation and floor slab requirements.

## REFERENCES

- [1] Afandi, R. (2021). Perencanaan Struktur Beton Bertulang Padang Bangunan Watchroom PKP-PK Dengan Sistem Rangka Pemikul Momen Khusus Di Bandar Udara Kelas 1 Utama Juwata -Tarakan. Surabaya : Politeknik Penerbangan Surabaya.
- [2] Badan Standardisasi Nasional . (2017). SNI 2052:2017 Baja Tulangan Beton. Jakarta : Badan Standardisasi Nasional.
- [3] Badan Standardisasi Nasional. (2018). Beban Desain Minimum Dan Kriteria Terkait Untuk Bangunan Gedung Dan Struktur Lain. Jakarta : Badan Standardisasi Nasional.
- [4] Badan Standardisasi Nasional . (2019). SNI 1726:2019 Tata Cara Perencanaan Ketahanan Gempa Untuk Struktur Bangunan. Jakarta: Badan Standardisasi Nasional .
- [5] Badan Standardisasi Nasional. (2019 ). SNI 2847:2019 Persyaratan Beton Struktural Bangunan Gedung. Jakarta : Badan Standardisasi Nasional .
- [6] Bidang IV Cipta Karya. (2023). Perkiraan Harga Satuan Kota Besar Di Indonesia. Jurnal Database Harga Satuan .
- [7] Indonesia, M. P. (2015). Standarisasi Dan Sertifikasi Fasilitas Bandar Udara .
- [8] Jurnal Harga Satuan Bahan Bangunan Kontruksi Dan Interior . (2022). Pandu Bangun Persada Nusantara.
- [9] Moreira, B. (2016). Perencanaan Struktur Beton Bertulang Dengan Sistem Rangka Pemikul Momen Khusus pada Bangunan Gedung Serbaguna Widya Bhakti Jl.Ijen Kota Malang. Malang : Institut Teknologi Nasional Malang.
- [10] Mukomoko, J. (1987). Dasar Penyusunan Anggaran Biaya . Jakarta : Jakarta : Gaya Media Pratama,1993.
- [11] Rambe, S. D. (2009). Perencanaan Struktur Gedung Beton Bertulang Sistem Rangka Pemikul Momen Khusus (SRPMK) Dan Sistem Rangka Pemikul Momen Menengah (SRPMM). Medan : Medan : Universitas Sumatra Utara.
- [12] Setiawam, R. B. (2017). Desain Struktur Gedung Venetian Menggunakan Metode SRPMK Dan Rencana Anggaran Biaya Lt 2. Surabaya : Institut Teknologi Sepuluh November.
- [13] Direktorat Jenderal Perhubungan Udara. (2011). Persyaratan Standard Teknis Dan Operasional Peraturan Keselamatan Penerbangan Sipil Bagian 139 (Manual Of Standard Casr Part 139) Volume IV, Pelayanan Pertolongan Kecelakaan Penerbangan Dan Pemadam Kebakaran (PKP-PK).
- [14] Direktorat Jenderal Perhubungan Udara. (2019). Standar Teknis Dan Operasional Peraturan Keselamatan Penerbangan Sipil Bagian 139 (*Manual Of Standard Casr - Part 139*) Volume I Bandar Udara (*Aerodrome*).
- [15] Direktorat Jenderal Perhubungan Udara. (2022). PR 30 Tentang Standar Teknis Dan Operasi Peraturan Keselamatan Penerbangan Sipil Bagian 139 (*Manual Of Standard CASR Part 139*) Volume IV Pelayanan Pertolongan Kecelakaan Penerbangan Dan Pemadam Kebakaran (PKP-PK).
- [16] Pragista, A. G., Wasito, B., & Suryono, W. (2022). Perencanaan Pelebaran Jalan Akses Unit PKP-PK Di Bandar Udara Dabo Singkep. In *Prosiding SNITP (Seminar Nasional Inovasi Teknologi Penerbangan)* (Vol. 6, No. 1).
- [17] Winiasri, L., Priyatna, N. J., & Harianto, B. B. (2021). Pengembangan Dan Analisis Media Pembelajaran Menggambar Teknik Menggunakan Macromedia Flash 8. *Jurnal Penelitian Politeknik Penerbangan Surabaya*, 6(2), 142-150.
- [18] X. Guo and L. Wu, "Experimental study on seismic behaviors of prefabricated embedded concrete-filled steel tube special-shaped column exterior frame," *European Journal of Environmental and Civil engineering*, pp. 1-23, 2022.
- [19] K. Prianto and B. Sadjab, "DISASTER RESILIENCE IN BUILDING CONSTRUCTION THROUGH CONCRETE CASTING METHODS: IMPLICATIONS FOR THE USE OF STRONG COLUMNS AND WEAK BEAMS," *Jurnal Pertahanan Media Informasi ttg Kajian & Strategi Pertahanan yang Mengedepankan Identity Nasionalism & Integrity*, 2021.
- [20] M. M. Shamszadeh, "Evaluation of strong column-weak beam criterion in spliced columns of steel moment frames," 2022.